



DOSING SYSTEMS
Solenoid Driven Dosing Pumps

HC 100

Technical Data Sheet
HC1 series



KEY FEATURES

- Stroke Frequency control 0-100% & 0-20%
- PTFE Diaphragm
- On-Off dosing control
- 2 LED display status
- Analogue Controls
- Economically Priced
- On-Off power switch
- Double ball valves as standard
- Lip valves on request
- Dosing Head with integral priming valve
- Wall Mount with bracket & fixing kit
- Reinforced Plastic PP housing
- Supplied complete with hose accessory kit

The **HC100** is a solenoid driven dosing pump, diaphragm actuated, for standard duties where a constant dosing operation with a reliable performance is required. Designed for either continuous or intermittent operation, they are a reliable means of conveying strong chemicals under precise control into water treatment and process systems. They operate on the well proven principle of electromagnetic drive, with electronic frequency control. Their frequency (stroking speed) is adjustable in 2 speed ranges selectable via a two position switch which is also mounted on the fascia.

PUMP CONTROL MODE

Constant mode: The pump flow rate is adjusted via a stroke frequency control knob and will constantly deliver according to the flow rate selected.

Double scale adjustment: for accurate control of low output: pump pulses reduction from 0÷100% to 0÷20%

LIQUID END MATERIAL HC100 SERIES

	Standard Version	Upon request
Pump head	PP	PVDF
Diaphragm	PTFE	-----
Valve balls	Glass Pyrex	AISI 316 – PTFE - CERAMIC
Valve cartridge	PP	PVDF
Spring loaded injection valve:	Hastelloy/Pyrex	Hastelloy/AISI316 - PTFE
Seals/O-rings	Viton®	Dutral® - NBR
Spring Loaded Injection Fitting	Hastelloy/Pyrex	Hastelloy (AISI 316 – PTFE - CERAMIC)
Injection Fitting	PP	PVDF
Foot Valve Strainer	PP	PVDF
Suction Hose /Air Bleed hose	PVC	PVDF
Discharge Hose	PE	PVDF
Upon request: Lip type valve	Viton®	Dutral® - NBR
Injection Sleeve-Non return Valve	Viton®	Dutral® - NBR

Viton®: FPM / Dutral®: EPDM, are registered trademarks of Dupont Elastomers

TECHNICAL CHARACTERISTICS HC1 SERIES

Model	Max Flow at		Stroke frequency per min.	Stroke volume ml / l	Stroke length mm	Power cons. watt	Hose size mm	Pump head (connections) model	Max suction lift m
	l/h	bar							
HC 100 01-08	1	8	105	0.16		20	4x6	PP 3/8"	1.5
HC 100 02-07	2	7	105	0.32	1.2	20	4x6	PP 3/8"	1.5
HC 100 04-05	4	5	105	0.64	1.1	20	4x6	PP 3/8"	1.5
HC 100 05-08	5	8	105	0.79	2.0	20	4x6	PP 3/8"	1.5

Model	Flow at max pressure		Flow at medium pressure		Flow at 1 bar	
	l/h	bar	l/h	bar	l/h	bar
01-08	1	8	4.5	4	7.5	1
02-07	2	7	5	3.5	8	1
04-05	5	5	6	2.5	9	1
05-08	5	8	7	4	10	1

NOTE: The flow rates opposite have been obtained by testing the pump with medium hardness water at a 1.5m suction lift at room temperature

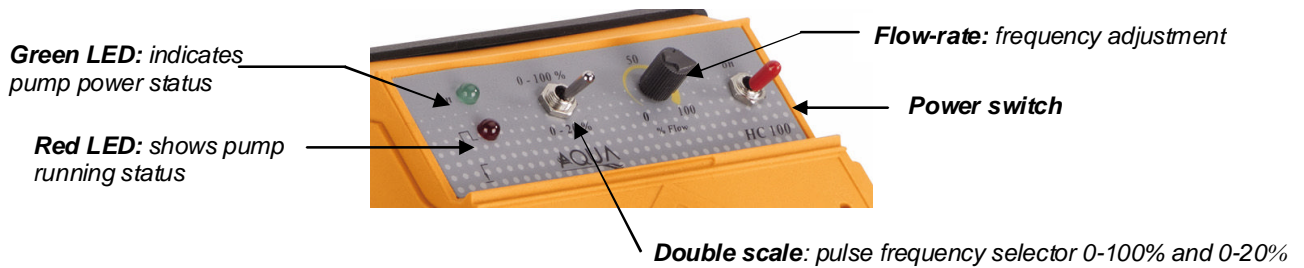

Power supply: 230 Vac - 1 phase - 50/60 Hz / ± 10%	Power cable: 3 m grounded without plug
Available upon request: 110 Vac - 1 phase - 60 Hz	Ambient working temperature: 45°C
Recommended frequency adjustment: 10 - 100%	Voltage working range: min 207v - Max 253v
Reproducibility under standard conditions: ± 5%	Voltage Peak: Max 270v
Plastic housing: PP reinforced	Wall mounting bracket: Polypropylene

HC100 is provided with a Standard Hose Accessory Kit:

- 1 No - PP Non return Injection fitting
- 2 m - Discharge Hose (PE)
- 2 m - PVC clear suction hose
- 1.5 m - PVC clear priming hose
- 1 No - PP Foot valve strainer with lip valve
- Screws and plugs for pump mounting bracket
- For Ball valve version:
- 1 No - Injection Valve- hastelloy spring -ball Pyrex

HC1 series

Dimension & Packing Details

- Packing weight: **2.5 - 3 kg**
- Packing size (mm): **220 x 170 x 210**
- Packing volume: **0.008 m3**

Now available-
Horizontal mount for HC series pumps

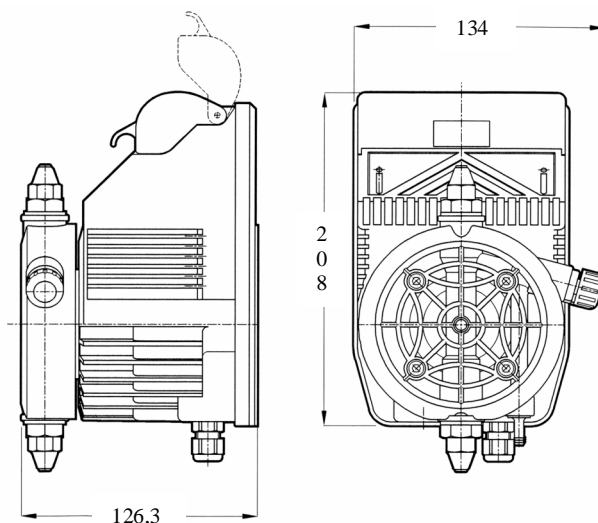

AQUA WATER SYSTEMS LTD
Units 3-6 - Hodfar Road - Sandy Lane Ind Est
Stourport-on-Severn - Worcestershire - DY13 9QB
Tel. : 01299 827703 - Fax : 01299 827704
email: sales@askaqua.co.uk Web: www.askaqua.co.uk

Technical Data Sheet
HC100