

**MANUALE DI PROGRAMMAZIONE
POMPA DOSATRICE**

**PROGRAMMING INSTRUCTIONS
FOR DOSING PUMP**

**NORME DE PROGRAMMATION
POMPE DOSEUSE**

**MANUAL DE INSTRUCCIONES
BOMBA DOSIFICADORAS**

**HC200 PH/RX 230V
HC300 PH/RX 230V**

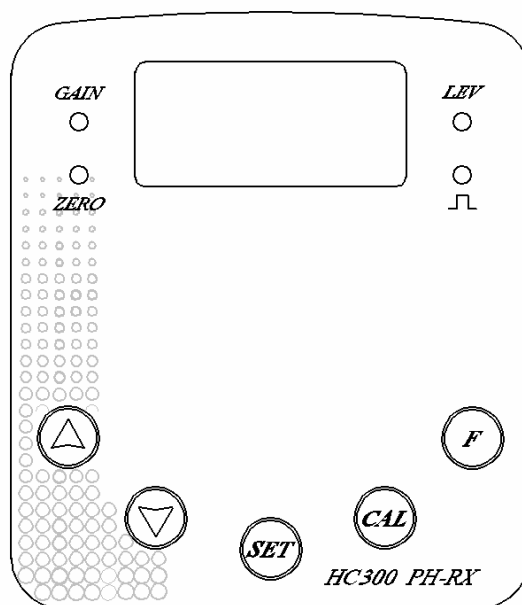
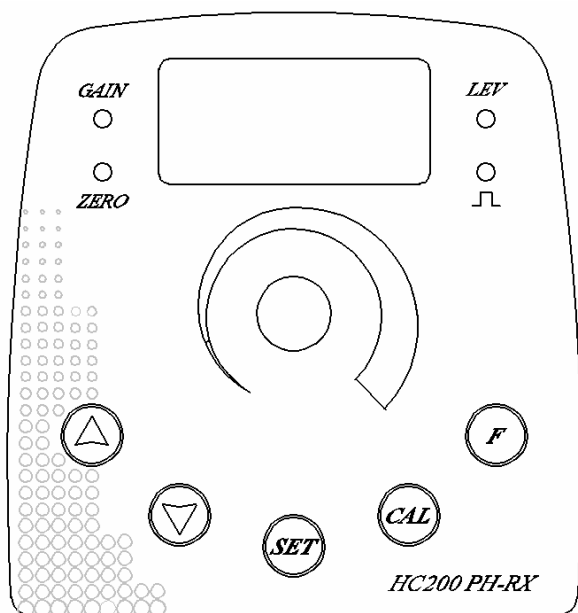

ENGLISH

Power supply

- Having installed the pump, with suction and discharge hoses in place, it can be connected to the correct power supply. Switching on the pump the display will show A 1 indicating that the software is functioning correctly.

pH – Rx Measuring

The pump can be used as pH or Rx, it can be connected to pH or Rx probe. To change the model of pump it must be set the functioning with F button up to reach **pH/ OrP**, with Up/Down push button it can be decided the model of pump: PH for pH behavior or OrP for Redox behavior (OrP = Oxygen reduction Potential).

Dosing regulation

- When the pump is working the stroke rate can be adjusted from 0 to 100% by using the **UP** and **DOWN** buttons on the front panel.

Calibration

pH mode

- Immerse the pH probe in pH 7 buffer solution and press the **CAL** button once, the red ZERO led will flash.
- Press the **UP** and **DOWN** buttons until the display shows 7pH. Press the **CAL** button to proceed with the calibration.
- Immerse the pH probe in the buffer solution 9 pH or 4 pH dependent on the direction of dosing, the red GAIN led will start flashing to indicate the regulation of the gain of the probe.
- Press the **UP** and **DOWN** buttons until you read the value of the buffer solution, and press the **CAL** button to confirm and go on with the setting of the manual temperature compensation.
- The display shows the temperature of the water analyzed (default 25°C), if you want to change this setting press **UP** and **DOWN** and confirm the choice by **CAL**.
- If during the calibration operation no button is pushed for 60 seconds the pump will automatically go back to normal run mode. By pushing **CAL** button it is possible to go back to calibration procedure if required.

Rx mode

- Immerse the Redox probe in your buffer solution eg. 544 mV and press the **CAL** button, the red ZERO led will flash to indicate programming of the zero.
- Press **UP** and **DOWN** buttons until the display will shows the value of the Buffer solution, eg 544mV. Press the **CAL** button to finish the calibration procedure.
- If during the calibration operation no button is pushed for 60 seconds the pump will automatically go back to normal run mode. By pushing the **CAL** button it is possible to go back to calibration procedure if required.

Set point regulation

- To program the set point of the pump push the **SET** button, the green ON LED will start flashing, the display will show the previous set value, press the **UP** and **DOWN** buttons to set your own value. Push the **SET** button to confirm this value when the pump will advance to hysteresis programming.
- The display will show the previous set value eg. 00H (minimum hysteresis +- 0.05 pH, +-7 mV), by pressing the **UP** and **DOWN** buttons it is possible to modify this parameter (eg. 01H hysteresis +- 0.1 pH, +-10 mV; eg. 10H hysteresis +- 1.00 pH, +-100 mV). Push the **SET** button to confirm your choice and advance to delay time programming.

- The display will show the previous set delay value (in seconds) starting from the activation or deactivation of the set point (eg. d02 = 2 seconds delay). By pressing the **UP** and **DOWN** buttons it is possible to modify the delay from 00 to 99 seconds (default d00= deactivated). Push the **SET** button to confirm the desired value and end set point programming.

Inversion of the regulation

- As Standard the pump will start dosing when the value drops lower than the set point. To change this press the F button and activate in function F1. (Eg F1 = A)

Dosing Range

- By activating the function F3 (F6_d) it is possible to operate between a range fixed by the hysteresis. Eg. with a set point of 7 pH and a hysteresis of 10 H (1,0 pH) you could operate between 6 and 8 (ON inside the window, OFF outside)(F1_d)
Eg. with the Set point fixed at 600 mV and hysteresis at 10H (100 mV) you could operate between 500 and 700 mV (OFF inside the window and ON outside) (F1_A).

Proportional functioning

pH mode

- By activating the function F6 you can change the operation from ON/OFF to proportional dosing. In this way the rate of pumping will be proportional to the deviation from the set point. For example if the set point is 7 pH and the reading is 3 pH the pump will run at the maximum frequency (the user can always modify the percentage of the flow by using the **UP** and **DOWN** buttons 0-100%). The pump will run at full frequency until it gets down to 4.00 pH (a difference from the set point of 3 pH) after this point it will start slowing the dose rate until completely stopping when the set point is reached. If you activate F7 it is possible to reduce this difference (from 3 pH to 1.50 pH). It is possible to reverse the direction of dosing as described in the programming section of this manual.

Rx mode

- By activating the function F6 you can change the operation from ON/OFF to proportional dosing. In this way the rate of pumping will be proportional to the deviation from the set point. For example if the set point is 700 mV and the reading is 250 mV the pump will run at the maximum frequency (the user can always modify the percentage of the flow by using the **UP** and **DOWN** buttons 0-100%). The pump will work at full frequency until it gets down to 450 mV (difference from the set point 250 mV), after this point it will start slowing the dose rate until completely stopping when the set point is reached. If you activate F7 it is possible to reduce this difference (from 250 to 125 mV). It is possible to reverse the direction of dosing as described in the programming section of this manual.

Functions

The programming functions can be activated or deactivated by the user, to make the pump suitable for different applications. The following paragraph explains how to set the functions along with a brief description, for further information please see programming section of this manual.

Function F1_d	Pump doses when lower than the set point*
Function F1_A	Pump doses when above the set point
Function F2	Not used
Function F3_d	Set point 1 setting with hysteresis. *
Function F3_A	Set point 1 operating within a window ON/OFF
Function F4	Not used
Function F5	Not used
Function F6_d	Pump doses in ON/OFF mode*

Function F6_A	Pump doses in Proportional mode
Function F7_d	Proportional dosing from set point over 3.00 pH (250mV). With F6 activated *
Function F7_A	Proportional dosing from set point over 1.50 pH (125mV). With F6 activated
Function F8.	pH or Rx functioning

* **Default factory value**

Activation/deactivation of the functions.

- Push the **F** button, the first two digits on the left of the display will show F1 on the right the display will show the function: d means Deactivated and A means Activated.
- By pressing the **UP** button it is possible to activate the function and with the **DOWN** button you can deactivate the function.
- To confirm the choice press **F**, if the value is changed this is recorded otherwise the pump moves to the next function F8 and ends the programming.
- If no button is pushed for 60 seconds the pump will automatically go back to run mode.

CONNECTIONS

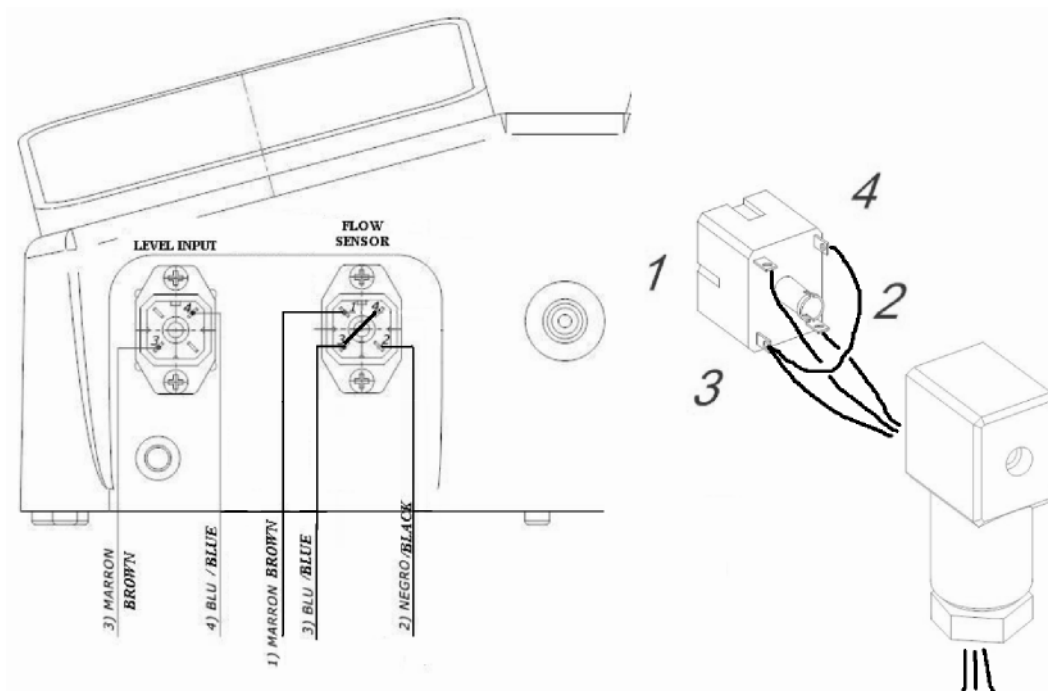

SCHEMA DI CONNESSIONE PER SENSORE DI PROSSIMITA' A-SP (ADSF)

1 *Brown*

2 *Black*

3 *Blue* ~ 4 (*~short circuit on 4*)

ENGLISH

FLOW SENSOR INPUT (OPTIONAL): if the pump has the flow sensor predisposition it will not dose without the connection with the flow sensor and without the correct water flow in the plant. In this case the level led will switch on and the pump will go in stand by state.

To use without flow sensor a pump that has the flow sensor predisposition it is necessary to:

- Open the female connector of the flow sensor
- Shortcut by a wire the contacts number 1 and 2, Shortcut by a wire the contacts number 3 and 4. -
- Close the female connector
- Put it on the male upon the box of the pump.