



DOSING SYSTEM
Solenoid Driven Dosing Pumps

HC 897

Technical Data Sheet
AQUA HC 897 Series



KEY FEATURES

- Heavy Duty Constant Flow Solenoid Driven Dosing Pump
- PTFE diaphragm and ball check valves
- Stroke frequency control 0 ~ 100%
- Constant / On-Off dosing mode
- Analogue Controls
- Single LED display status
- Dual frequency range: 0 ~100% - 0 ~20%
- On-Off power switch
- Air Bleed valve for priming
- Low-Level control facility
- Supplied with horizontal and vertical mount brackets
- Reinforced PPE housing
- Supplied with complete accessory Kit (ref. list)
- Power Supply: 230V±10% - 50/60hz
- IP 65 protection

HC897 is a constant flow rate solenoid driven dosing pump, is supplied standard with PTFE diaphragm, PTFE balls and Viton seals and the pump operate at 150 pulses/minutes. Designed for either continuous or intermittent operation, they are a reliable means of conveying strong chemicals under precise control into water treatment and process systems. This pump work with a stroke frequency control 0 ~ 100% and the standard power supply is 230vAC and 110vAC 50/60 Hz.

Constant mode: The pump flow rate is adjusted via a strokes frequency knob. The pump will constantly perform the dosing operation according to the flow rate selected by the selected frequency.

Double scale adjustment: for accurate control of flow, a pump pulses reduction selector from 0-100% to 0-20%.

LIQUID ENDS MATERIAL		
	Standard Version	Upon request
Pump head	PVDF	PP
Diaphragm	PTFE	-----
Ball check valves	PTFE	Ceramic, Glass Pyrex
Connection fitting	PVDF	PP
Seals/O-rings	Viton®	Dutral®
Injection Fitting	PVDF	PP
Foot Valve/Filter Fitting	PVDF	PP
Upon request: Lip valves	Viton®	Dutral®

TECHNICAL CHARACTERISTICS HC897 SERIES

Model	Max Flow @		Stroke frequency per min.	Stroke volume ml / pulse	Power cons. watt	Hose size mm	Pump head model
	l/h	bar					
HC897 - 1	2	8	150	0.22	15	4x6	PVDF 1/2"
	5	5		0.55			
	7	2		0.77			
HC897 - 2	7	4	150	0.77	15	4x6	PVDF 1/2"
	8	2		0.88			
	10	0		1.11			
HC897 - 3	3	12	150	0.33	20	4x6	PVDF 1/2"
	4	10		0.44			
	5	8		0.55			
HC897 - 4	10	4	180	0.93	20	4x6	PVDF 1/2"
	12	2		1.11			
	14	0		1.29			

Flow-rate: Dual rate frequency adjustment control from 0 to 100%
0 to 20%

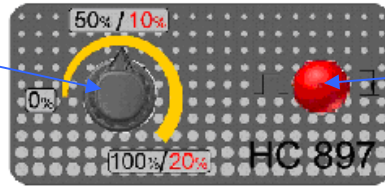

Red LED: shows pumps Running status

Power supply: **220-230 V ± 10% -50/60 Hz**

Power cable: **3 m grounded without plug**

Voltage Peak: **Max 270 V**

Ambient working temperature: **45°C**

Recommended frequency adjustment: **10 ÷100%**

Voltage working range: **min.207V – Max 253 V**

Plastic housing: **PPE**

Wall mounting bracket: **PP**

Standard Accessory Kit:

1 No PVDF ball valve Injection fitting (½ “ BSPM)

1 No PVDF Foot Valve with ball valve

1 No PE Discharge Hose 2m x 4/6mm

1 No PVC Crystal Air Bleed Hose 15m x 4/6mm

1 No PVC Crystal Suction Hose 2m x 4/6mm

Power supply: 230 Vac–single phase– 50/60 Hz / ± 10%

HC897 series Wall Mounting dimensions and packing

Dimension (mm): **112 x 188 x 128**

Packing weight: **2 kg**

Packing size (mm): **240 x 175 x 148**

Packing volume: **0.006 m3**

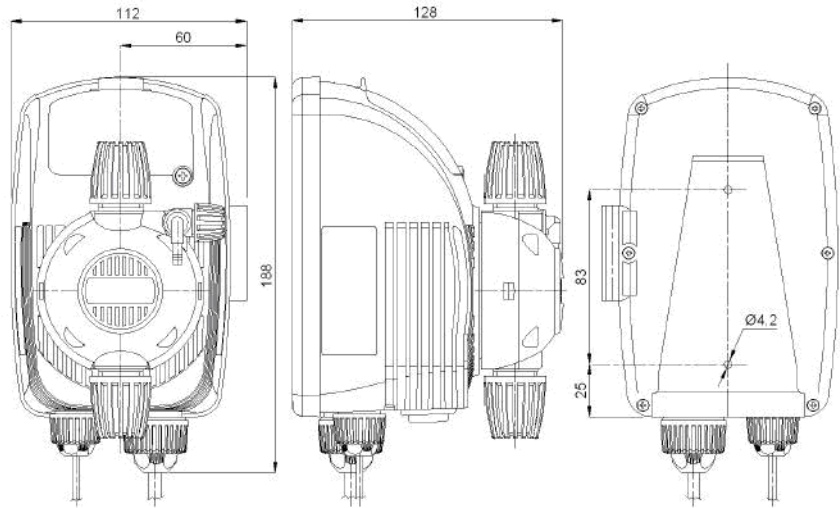

Figure 1: When used with vertical mount bracket

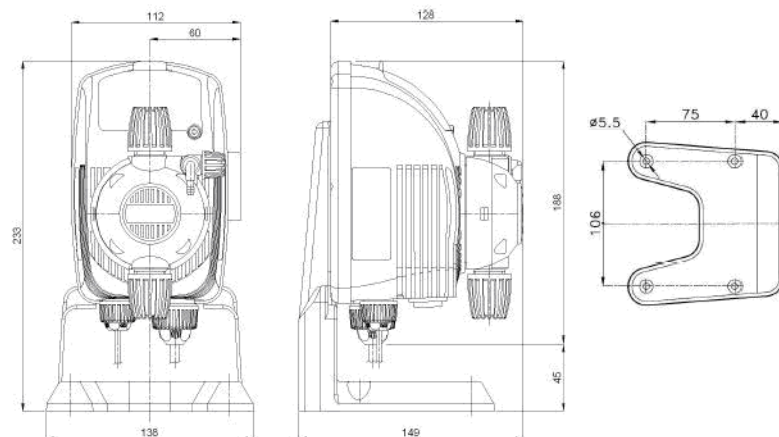

Figure 2: When used with horizontal mount bracket



AQUA WATER SYSTEMS LTD
Units 3-6 - Hodfar Road - Sandy Lane Ind Est
Stourport-on-Severn – Worcestershire – DY13 9QB
Tel. : 01299 827703 - Fax : 01299 827704
email: sales@askaqua.co.uk Web: www.askaqua.co.uk

Technical Data Sheet
HC897